

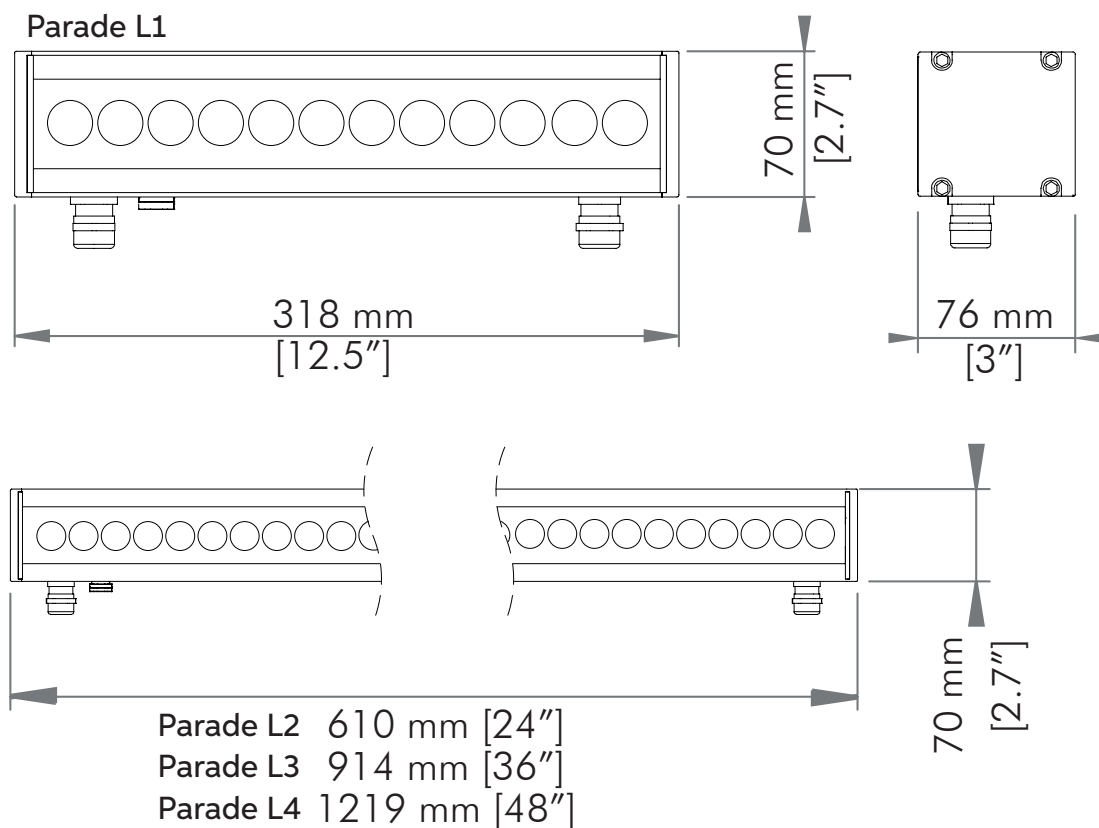

| | Parade L1 | Parade L2 | Parade L3 | Parade L4 |
|--|---|--|--|--|
| Code | AL5060 - AL5061 (PE) | AL5065 - AL5066 (PE) | AL5070 - AL5071 (PE) | AL5075 - AL5076 (PE) |
| Power consumption Consumo di energia | 20W (RN) 19W (DW) 19W (W) | 38W (RN) 38W (DW) 37W (W) | 58W (RN) 57W (DW) 56W (W) | 79W (RN) 76W (DW) 75W (W) |
| Nominal current Corrente nominale | 0.1A (RN) 0.1A (DW) 0.1A (W) @230Vac | 0.17A (RN) 0.17A (DW) 0.17A (W) @230Vac | 0.26A (RN) 0.26A (DW) 0.25A (W) @230Vac | 0.35A (RN) 0.34A (DW) 0.34A (W) @230Vac |
| Power supply Alimentazione elettrica | 220-240VAC 50/60Hz | | | |
| Inrush current Corrente di spunto | 23.42 A @240VAC, 25°C | | 27.5 A @240VAC, 25°C | |
| Power factor Fattore di potenza | cos.φ= 0.87 | cos.φ= 0.94 | cos.φ= 0.95 | cos.φ= 0.97 |
| Electrical class Classe elettrica | I - (Class II option) / (Opzione classe II) | | | |
| Weight / Peso | 2.1 Kg | 3.1 Kg | 4.4 Kg | 5.6 Kg |
| Operating temperature Temp. funzionamento | -40°C to +50°C (-40°F to 122°F) | | | |
| IP rating / Grado IP | IP67 | | | |
| IK rating / Grado IK | IK09 | IK10 | IK09 | IK10 |

Dimensions / Dimensioni



Important notices - Avvisi importanti

- This product must be installed in accordance with applicable national and local electrical and construction codes by a person familiar with the construction and operation of the product and the hazards involved. Failure to comply with the following installation instructions may result in death or serious injury.
- Do not stare at the operating light source.
- The fixture might be damaged by excess voltage. The installation of an overvoltage protection device on the electrical system (SPD) is recommended for reduce the risk of damage.
- The use of an adequate magnetothermic switch along the power supply line is recommended.
- Connect the fixtures to each other only when disconnected from mains.
- Never leave cables and connectors unconnected or unprotected for long periods.
- Disconnect power before installing or servicing to avoid electrical shock.
- Disconnect power before any connection operation.
- Check voltage and frequency before powering the fixture. Do not exceed fixture specified voltage.
- Do not handle the unit with wet hands or in wet environments.
- Apply to qualified staff for any maintenance service not described in this instructions manual.
- Do not exceed the maximum quantity of fixtures per line in order to avoid power surges.
- Before powering the unit, ensure to use cables and connectors with proper section and length, according to its power consumption.
- Fix the projector by using screws, hooks or other adequate supports that can bear its weight.
- If the external flexible cable of this appliance is damaged, it must only be replaced by the manufacturer, its assistance service or equivalent qualified personnel in order to avoid hazards.
- Integrated temperature control, the projector reduces power when $T_a > 35^\circ\text{C}$.
- The luminaire should be positioned so that prolonged observation of the luminaire at a distance of less than 2 meters (6.56 ft) is not expected.
- All devices connected to the DALI bus must be SELV type.

- Questo prodotto deve essere installato secondo le normative locali, da personale specializzato. La mancata osservanza delle istruzioni di installazione può portare a situazioni di pericolo all'incolumità della persona.
- Non fissare la sorgente luminosa durante il suo funzionamento.
- Apparecchiatura sensibile alle sovratensioni. Si consiglia l'installazione di un dispositivo di protezione delle sovratensioni (SPD) sull'impianto elettrico per attenuare l'intensità di questi fenomeni proteggendo gli apparecchi dal rischio che vengano danneggiati.
- E' consigliato l'uso di un adeguato interruttore magnetotermico/differenziale sulla linea di alimentazione.
- Collegare tra loro i proiettori solo quando nessuno di essi è collegato alla rete elettrica.
- Non lasciare mai per lungo tempo agli agenti atmosferici cavi e connettori non collegati o non protetti.
- Togliere l'alimentazione prima di effettuare qualsiasi operazione all'interno dell'apparecchiatura.
- Togliere l'alimentazione prima di effettuare qualsiasi operazione di connessione tra gli apparecchi.
- Prima di connettere l'apparecchio alla rete elettrica, verificate la compatibilità di tensione e frequenza.
- Non maneggiate il prodotto con mani bagnate o in presenza di acqua.
- Rivolgersi ad un tecnico qualificato per qualsiasi operazione di manutenzione ordinaria non descritta nel presente manuale.
- Non superare il numero massimo specificato di apparecchi per linea per evitare pericolosi sovraccarichi di corrente.
- Prima di effettuare le connessioni verificare la portata dei cavi / connettori e la lunghezza dei cavi tenendo conto dell'assorbimento del prodotto.
- Fissare il proiettore con viti, ganci o altri supporti in grado di sostenerne il peso.
- Se il cavo flessibile esterno di questo apparecchio viene danneggiato, deve essere sostituito esclusivamente dal produttore, dal suo servizio di assistenza o da personale qualificato equivalente, al fine di evitare pericoli.
- Controllo della temperatura integrato, il proiettore reduce la potenza ad una $T_a > 35^\circ\text{C}$
- l'apparecchio di illuminazione dovrebbe essere posizionato in modo che non sia prevista un'osservazione prolungata dell'apparecchio ad una distanza inferiore a 2 metri.
- Tutte le apparecchiature connesse al bus DALI devono essere di tipo SELV.



CAUTION! The luminaire should be positioned so that prolonged staring into the luminaire at a distance closer than 9 meters is not expected.

ATTENZIONE! L'apparecchio deve essere posizionato in modo che non si possa fissarlo a lungo a una distanza inferiore a 9 metri.



WARNING! Fixing and connecting operations must mandatorily be carried out by qualified personnel only!



ATTENZIONE! Le operazioni di fissaggio e collegamento devono essere eseguite solo e obbligatoriamente da personale qualificato!



WARNING! Make sure that power supply is off before connecting or disconnecting fixtures!



ATTENZIONE! Assicurarsi che l'alimentazione sia spenta prima di collegare o scollegare i dispositivi!



The possibility of reusing some electrical parts of the device is subject to the total responsibility of the user. The label shows the symbol indicated in Legislative Decree n.49 of 14 March 2014 which transposes Directive 2012/19 / EU, which indicates the need to dispose of the product in separate waste, specifically in electrical waste. and electronic. Refer to the waste collection center located in your area.



La possibilità di riutilizzare alcune parti elettriche del dispositivo è subordinata alla totale responsabilità dell'utilizzatore. Nell'etichetta è stato riportato il simbolo indicato nel D.lgs n.49 del 14 Marzo 2014 che recepisce la direttiva 2012/19/UE, il quale indica la necessità di smaltire il prodotto nei rifiuti differenziati, nello specifico nei rifiuti di tipo elettrico ed elettronico. Fare riferimento al centro di raccolta rifiuti situato nella Vostra zona.



Replaceable control gear by a professional



Alimentatore sostituibile da un professionista



Replaceable (LED only) light source by a professional



Sorgente luminosa (solo LED) sostituibile da un professionista

This product contains a light source of energy efficiency class:

Questo prodotto contiene una sorgente luminosa di classe di efficienza energetica:

| | | | |
|-------|-------|---------------|------------|
| 3000K | 4000K | Dynamic White | RGBW 4000K |
| F | F | E | F |

Connection - Connessione

“C” Type cables (Hybrid cables + connectors)

Cavi tipo “C” (Cavi ibridi + connettori)

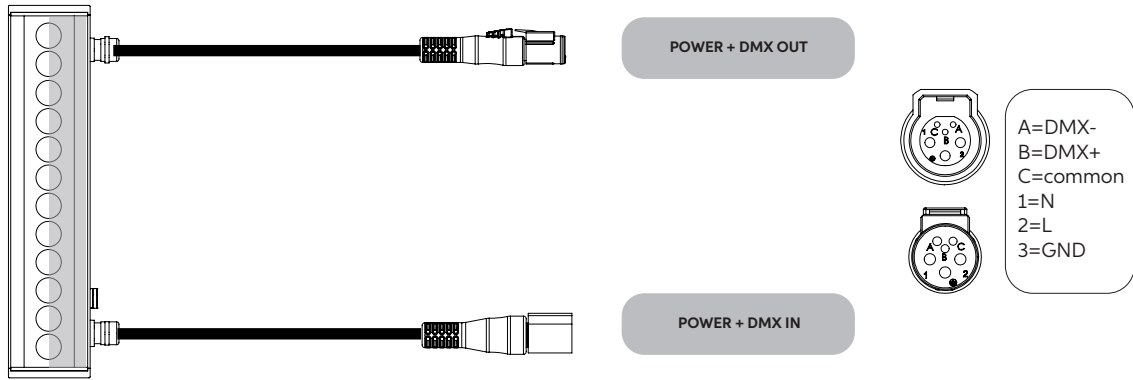

“M” Type cables (Hybrid cables without connectors - DMX)

Cavi tipo “M” (Cavi ibridi senza connettori - DMX)

Class II (option)

Classe II (opzionale)

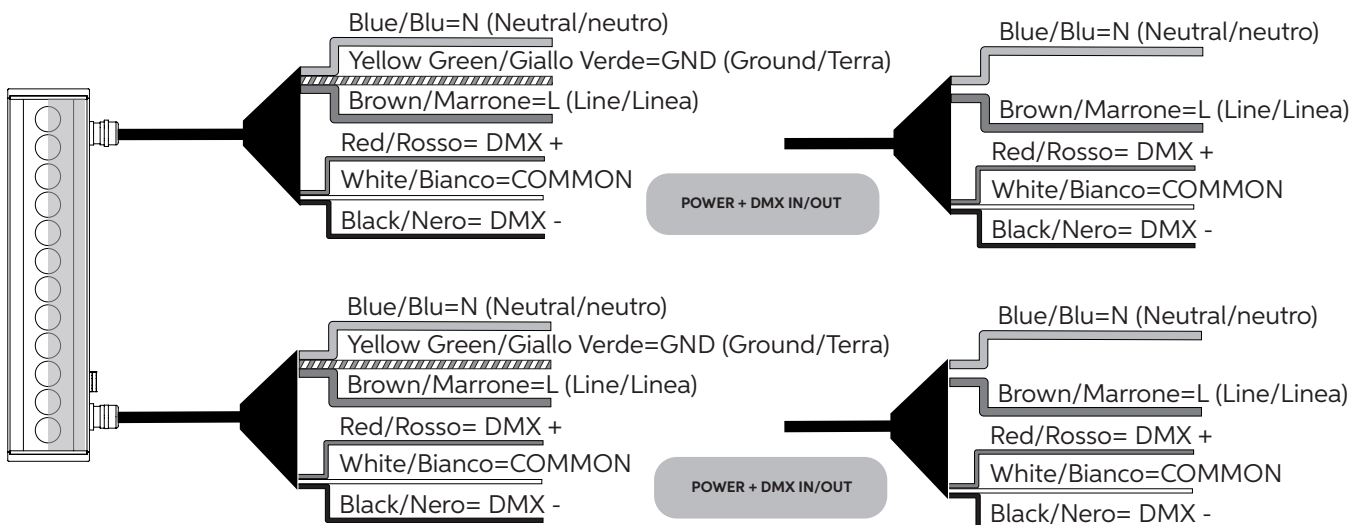

“M” Type cables (Hybrid cables without connectors - DALI)

Cavi tipo “M” (Cavi ibridi senza connettori - DALI)

Class II (option)

Classe II (opzionale)

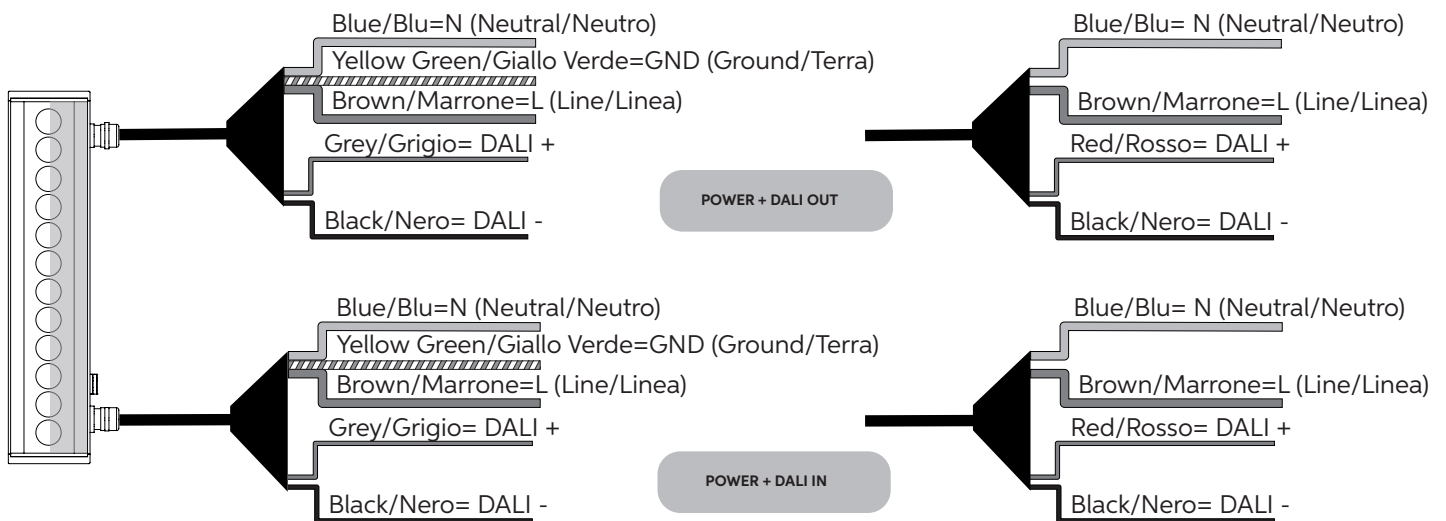

ATTENZIONE - WARNING

ITA: I collegamenti dei cavi di tipo “S” ed “M” devono essere effettuati utilizzando il kit di collegamento **da ordinare separatamente**. Seguire le istruzioni fornite insieme al kit di connessione.

EN: The connections of the cables type “S” and “M” must be made using the connection kit **to be ordered separately**. Follow the instructions provided with the connection kit.

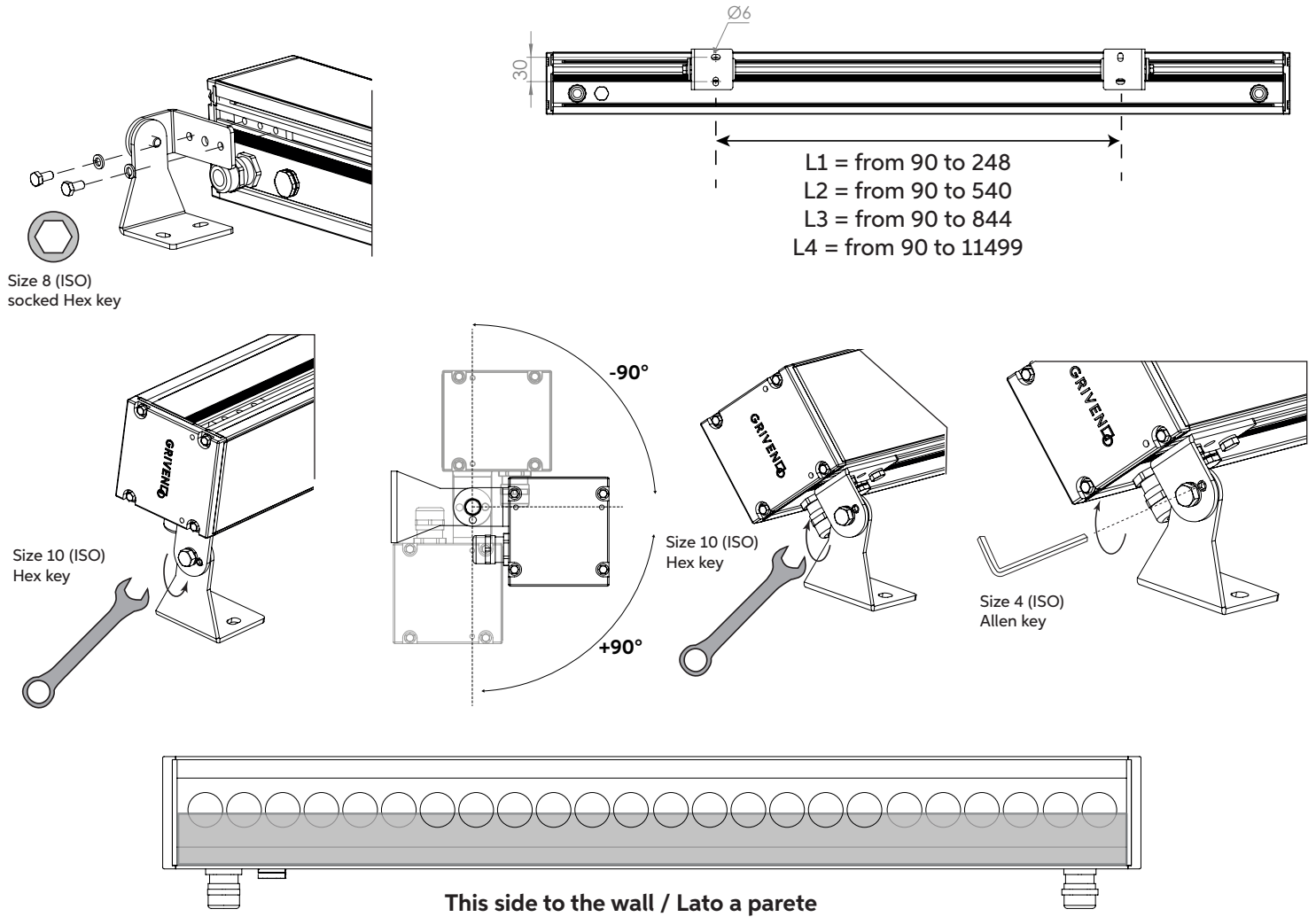

For 3G applications, consider the distances informed bellow:
Per le applicazioni 3G, considerare le distanze informate sotto:

| | |
|------------------------------------|--|
| Parade L-1 (A= 8cm, B= 8cm) | |
| Parade L-2 (A= 15cm, B= 15cm) | |
| Parade L-3 (A= 22,5cm , B= 22,5cm) | |
| Parade L-4 (A= 30cm , B= 30cm) | |

Polar features (only on Polar Edition fixtures)

The POLAR Edition is fitted with a thermal glass which is particularly useful for outdoor applications. In fact, by warming up, the glass melts ice and snow which might interfere with the projection. When the projector is on, if required by the weather conditions, the glass is automatically warmed up.

WARNING: If the projection is to be started at a definite time, take care to defrost the glass in advance so that the LEDs can be lit at the time required.

WARNING: At very low temperatures (below -20° C), it is recommended to let the fixture always powered and to switch on the LEDs when needed.

Fixture configuration / Configurazione dell'apparecchio

The equipment can be configured using **IR remote control AL1321** (sold separately) or via any DMX-RDM compatible controller.

L'apparecchiatura può essere configurato utilizzando il **telecomando IR AL1321** (venduto separatamente) o tramite qualsiasi controller compatibile DMX-RDM.

DMX Chart

RGBW

| Mode | Channel | Function | Value | |
|------------|------------|-------------------|-------------------|-------|
| #1 IR=4 | 1 | 0-100% Red | 0-255 | |
| | 2 | 0-100% Green | 0-255 | |
| | 3 | 0-100% Blue | 0-255 | |
| | 4 | 0-100% White | 0-255 | |
| #2 IR=5 | 1 | 0-100% Red | 0-255 | |
| | 2 | 0-100% Green | 0-255 | |
| | 3 | 0-100% Blue | 0-255 | |
| | 4 | 0-100% White | 0-255 | |
| | 5 | 0→100% Dimmer | 0-255 | |
| #3 IR=6 | 1 | 0-100% Red | 0-255 | |
| | 2 | 0-100% Green | 0-255 | |
| | 3 | 0-100% Blue | 0-255 | |
| | 4 | 0-100% White | 0-255 | |
| | 5 | 0% Dimmer | 0-5 | |
| | | 100-0% Dimmer | 6-250 | |
| | | 100% Dimmer | 251-255 | |
| | 6 | No Strobe | 0-5 | |
| | | 0-100% Strobe | 6-250 | |
| | | 100% Strobe | 251-255 | |
| #4 IR=7 | 1 | 0-100% Red | 0-255 | |
| | 2 | 0-100% Green | 0-255 | |
| | 3 | 0-100% Blue | 0-255 | |
| | 4 | 0-100% White | 0-255 | |
| | 5 | NO FUNCTION | 0-5 | |
| | | 2700K | 6-7 | |
| | | 2700K→3000K | 8-40 | |
| | | 3000K | 41-42 | |
| | | 3000K→3500K | 43-75 | |
| | | 3500K | 76-77 | |
| | | 3500K→4000K | 78-110 | |
| | | 4000K | 111-112 | |
| | | 4000K→4500K | 113-145 | |
| | | 4500K | 146-147 | |
| | | 4500K→5000K | 148-179 | |
| | | 5000K | 180-181 | |
| | | 5000K→5500K | 182-214 | |
| | | 5500K | 215-216 | |
| | | 5500K→6000K | 217-249 | |
| | 6000K | 250-255 | | |
| | 6 | 0→100% Dimmer | 0-255 | |
| | #5 IR=8 | 1 | 0-100% Red | 0-255 |
| | | 2 | 0-100% Red fine | 0-255 |
| | | 3 | 0-100% Green | 0-255 |
| | | 4 | 0-100% Green fine | 0-255 |
| | | 5 | 0-100% Blue | 0-255 |
| | | 6 | 0-100% Blue fine | 0-255 |
| 7 | | 0-100% White | 0-255 | |
| 8 | | 0-100% White fine | 0-255 | |

| Mode | Channel | Function | Value |
|-------------------------|---------|---|-------|
| #6 IR=9 (Default) | 1 | 0-100% Red | 0-255 |
| | 2 | 0-100% Green | 0-255 |
| | 3 | 0-100% Blue | 0-255 |
| | 4 | 0-100% Calibrated White (Affects RGB channels) | 0-255 |

Note: in absence of DMX signal the LEDs will remain **OFF**.

DW (Dynamic White)

| Mode | Channel | Function | Value |
|-------------------------|---------|-------------------------|-------|
| #1 IR=2 (Default) | 1 | 0%→100% Warm white | 0-255 |
| | 2 | 0%→100% Cold White | 0-255 |
| #2 IR=3 | 1 | 0%→100% Warm white | 0-255 |
| | 2 | 0%→100% Cold white | 0-255 |
| | 3 | 0%→100% dimmer | 0-255 |
| #3 IR=3 | 1 | 0%→100% Warm white | 0-255 |
| | 2 | 0%→100% Warm white fine | 0-255 |
| | 3 | 0%→100% Cold white | 0-255 |
| | 4 | 0%→100% Cold White fine | 0-255 |

Note: in absence of DMX signal the LEDs will remain **ON**.

Monochromatic version

| Channel | Function | Value |
|---------|----------------|-------|
| 1 | 0%→100% dimmer | 0-255 |

Note: in absence of DMX signal the LEDs will remain **ON**.

Independent pixels

Nelle versioni "Independent pixels" le funzioni citate nelle precedenti tabelle vengono ripetute per il numero di moduli dell'apparecchio. Es. Parade L3 RGBW nella modalità #1 impegna 12 canali. In the "Independent pixels" versions, the functions mentioned in the previous tables are repeated for the number of modules in the device. E.g. Parade L3 RGBW in mode #1 engages 12 channels.

RDM functions

When operating in DMX mode the fixture can accept the following RDM commands:

- Discovery: Upon request of the RDM controller, the fixture signals its own presence (the RDM controller will display the fixture on a list).
- DMX address reading and setting.
- Channels number reading and setting.
- On / Off identification: This command is used to identify the fixture you want to get access to (the identification happens by switching on all the LEDs at full intensity).
- Manufacturer: it displays the name of the manufacturer (Griven).
- Model description: it displays the fixture's model.
- Software version description: it displays the current version of the firmware.
- Temperature: it displays the LEDs operating temperature value.

Configuration examples / Esempi di configurazioni

Single Chain Configuration

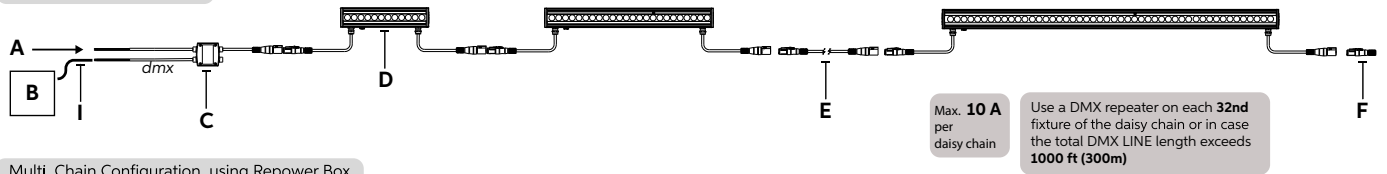

Multi Chain Configuration using Repower Box

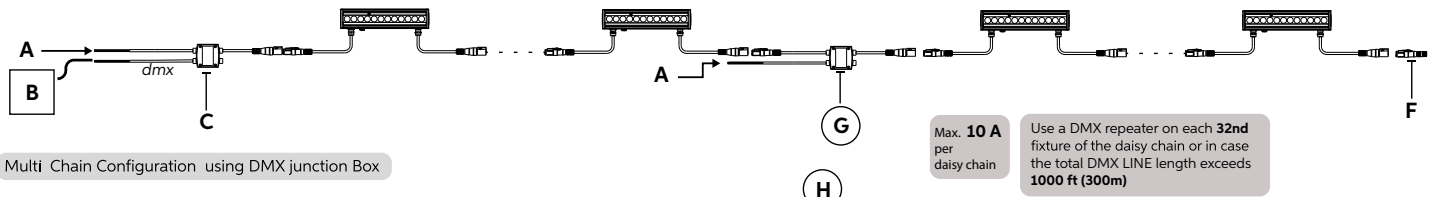

Multi Chain Configuration using DMX junction Box

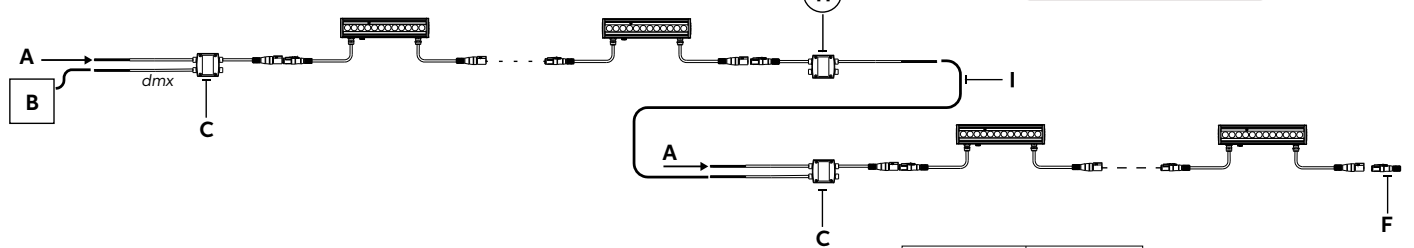

- A - Power Input
- B - DMX/RDM Controller
- C - Start Line Box - AL5058C with connectors / AL5058M without connectors
- D - Parade L-1, L-2, L-3, L-4, L-2 Recessed, L-3 Recessed
- E - Connection Cable - AL8264 L=1m AL8265 L=2m AL8266 L=3m AL8267 L=5m AL8268 L=10m
- F - DMX Terminator - AL5169
- G - Repower Box - AL5167C with connectos / AL5167M without connectors
- H - DMX Junction Box - AL5059C with connectors / AL5059M without connectors
- I - DMX Cable - AL0512

| CE Colours | USE |
|--------------|------------|
| Brown | Live |
| Blue | Neutral |
| Yellow/Green | Ground |
| Red | DMX Data + |
| Black | DMX Data - |
| White | DMX GND |

Operating modes / Modalità operative

DMX Mode

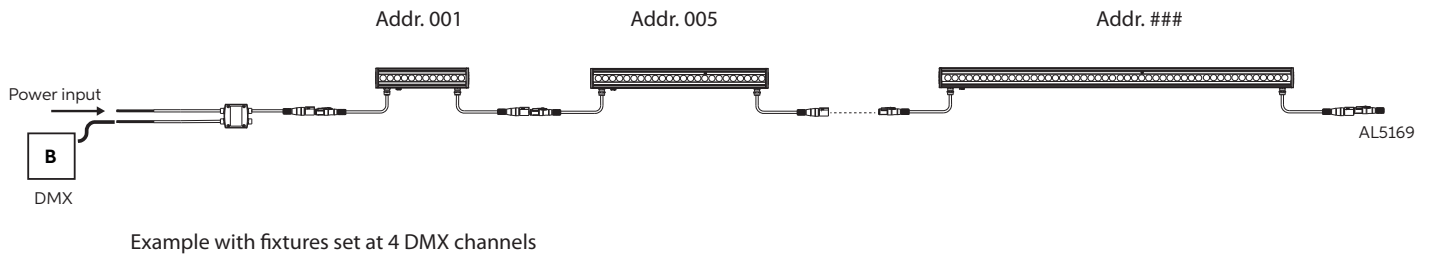

Master-Slave / Automatic / Fixed color Mode

(Only DMX Mode #1)

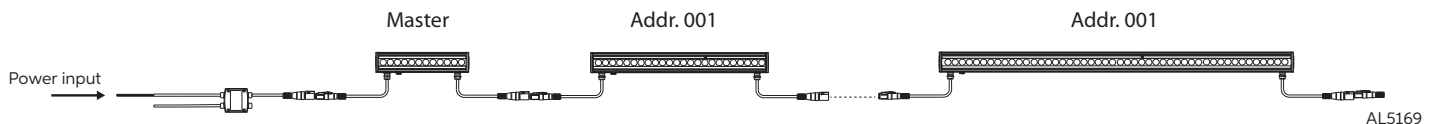

WARNING ! in this mode, no DMX control device must be present along the line.
ATTENZIONE ! in questa modalità non deve essere presente lungo la linea nessun altro dispositivo di controllo DMX.

| Addresses and loads Dali / Indirizzi e carichi Dali | | | |
|---|------|----------|-------------|
| Product type / Prodotti tipo | Dali | Dali DT8 | Carico Load |
| Monochromatic / Monocromatico | 1 | | 2mA |
| Dinamic white / Bianco diamico | 2 | 1 | 2mA |
| RGBW | 4 | 1 | 2mA |